

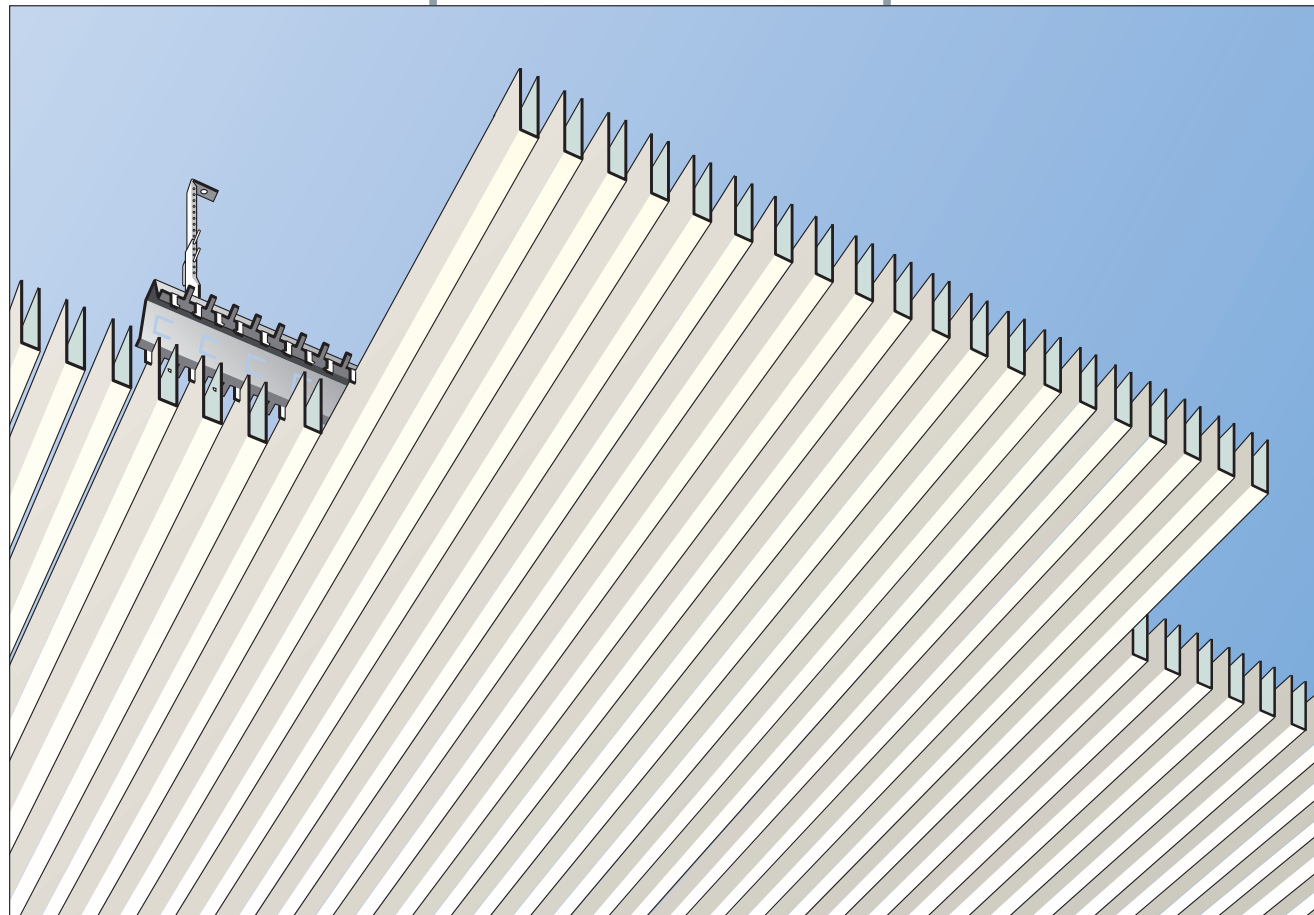

NordProfil



Linus

LINEAR METAL 'U' FORMATION
SCREEN PROFILE RANGE

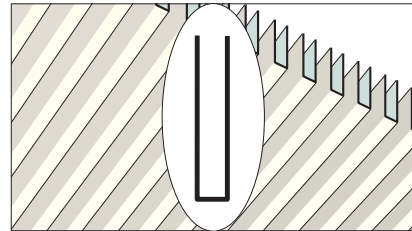

1

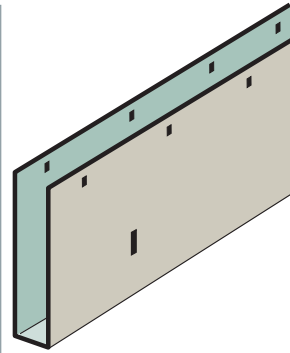

Folded aluminium or zinc coated mild steel in thicknesses shown in Table 2 with minuscule fixing slots at 38mm centres on both sides.

Subject to requirements perforated LINUS profiles may have black tissue lining bonded to their internal surfaces.

Standard finish: stove enamel polyester paint in matt, semi gloss or full gloss (see colour chart).

Colours: standard as colour chart no's 137 white 901 white (RAL 9010 approx).

18 silver metallic (RAL 9006 approx).

117 clear lack (alum. only) **Special finishes:** subject to minimum order quantity.

Max. length: 3000mm

Table 2 Linus profile sizes and metal thicknesses..
W = profile width mm.
H = profile height mm.
Al = aluminium thickness mm.
St = steel thickness mm.

Ref	W	H	Al	St
L 10H30	10	30	0.4	0.3
L 10H40	10	40	0.4	0.3
L 10H50	10	50	0.5	0.3
L 10H60	10	60	0.5	0.3
L 12H40	12	40	0.4	0.3
L 12H50	12	50	0.5	0.3
L 12H60	12	60	0.5	0.3
L 15H40	15	40	0.4	0.3
L 15H50	15	50	0.5	0.3
L 15H55	15	55	0.5	0.3
L 15H80	15	80	0.6	0.3
L 20H35	20	35	0.4	0.3
L 20H45	20	45	0.5	0.3
L 20H55	20	55	0.5	0.3
L 20H80	20	80	0.6	0.3
L 24H35	24	35	0.5	0.3
L 24H45	24	45	0.5	0.3
L 24H50	24	50	0.5	0.3
L 24H80	24	80	0.6	0.3



STANDARD PERFORATION
2mm diameter holes on diagonal grid. 15% open area.

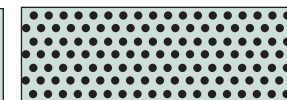

MICRO PERFORATION
1.3mm diameter holes on diagonal grid. 22% open area.

1A

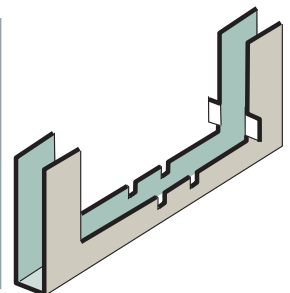

SPLICE CHANNEL for (1) Linus profiles, 125 mm long made of 1 mm galvanised steel.

Linus profiles should preferably be coupled at a carrier using this splice channel (see also figure 7).

2

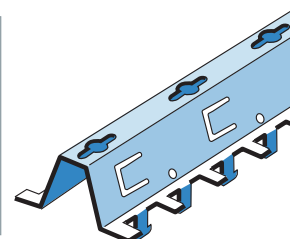

OMEGA carriers in cold roll formed 0.6mm thick galvanised mild steel, Tongue spacings to suit standard LINUS modules A-G.

Overall size: 25mm deep x 53mm wide.

Standard finish: matt black polyester stove enamel paint.
Standard lengths: 4000mm.

2A

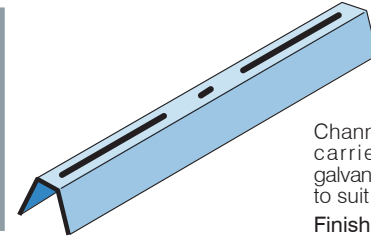

Channel coupler for OMEGA carriers in 0.6mm thick galvanised mild steel and length to suit tongue module.

Finish: as OMEGA carrier.

3A

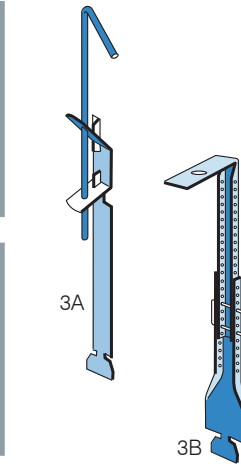

Butterfly suspension key hanger in 1.5mm thick galvanised mild steel with spring clips and 4mm dia. rod.

Standard lengths: various between 125mm min. and 1000mm max. ceiling void depths.

Vernier hanger upper section in 1.0mm thick galvanised mild steel, paint finished, with 1.25mm thick galvanised mild steel bracket and 2.5mm dia. steel looped security pin.

Standard lengths: 2000mm upper section VERNIER hanger has section edges vee notched to provide 'easy break' positions at 62mm centres.

3B

4

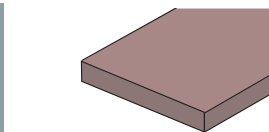

Standard 25mm thick 45kg/m³ density rockwool or 20mm thick 20kg/m³ density glasswool, both with black tissue face.

5i

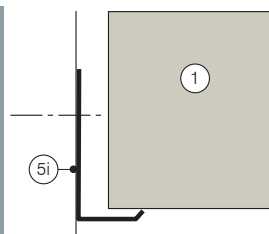

OPTIONAL WALL ANGLE
Perimeter angle trim in cold roll formed 0.7mm thick aluminium.

Standard finish: stove enamel polyester paint to match LINUS profiles applied to all surfaces.

Standard length: 4000mm
Overall size: 40mm deep x 20mm wide.

5ii

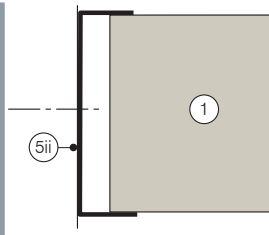

OPTIONAL WALL CHANNEL
Perimeter channel trim in press braked 0.4/0.5mm thick aluminium or steel 0.3mm.

Standard finish: stove enamel polyester paint to match LINUS profiles applied to all surfaces.

Standard length: 1800mm
Overall size: height to suit height of LINUS profiles with 2 no's legs to suit LINUS profile widths.

6

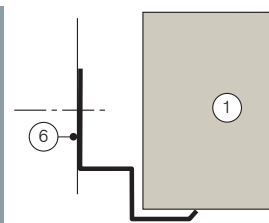

OPTIONAL WALL ANGLE
Perimeter shadow line angle trim in cold roll formed 0.7mm thick aluminium.

Standard finish: stove enamel polyester paint to match LINUS profiles applied to all surfaces.

Standard length: 4000mm
Overall size: 44mm deep x 36.5mm wide, shadow gap width = 12.5mm.

7

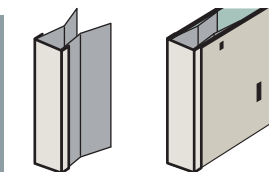

Slide in ENDCAPS in folded aluminium or zinc-coated mild steel.

Standard finish as the profiles.

Nord Profil Deutschland GmbH & Co. KG
Meteler Stiege 51-57
48565 STEINFURT
Germany
Tel.: (+49)-2551 864 600
Fax: (+49)-2551 864 6020
E-mail: info@nordprofil.com
Internet: www.nordprofil.com

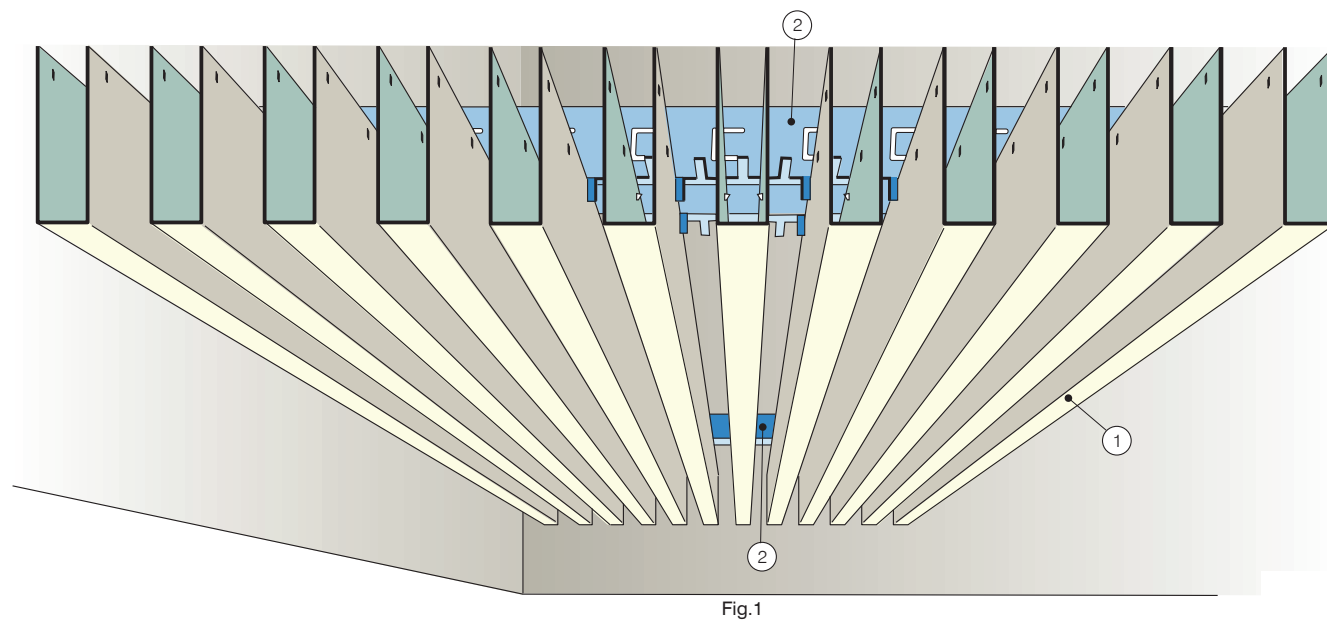

Fig.1

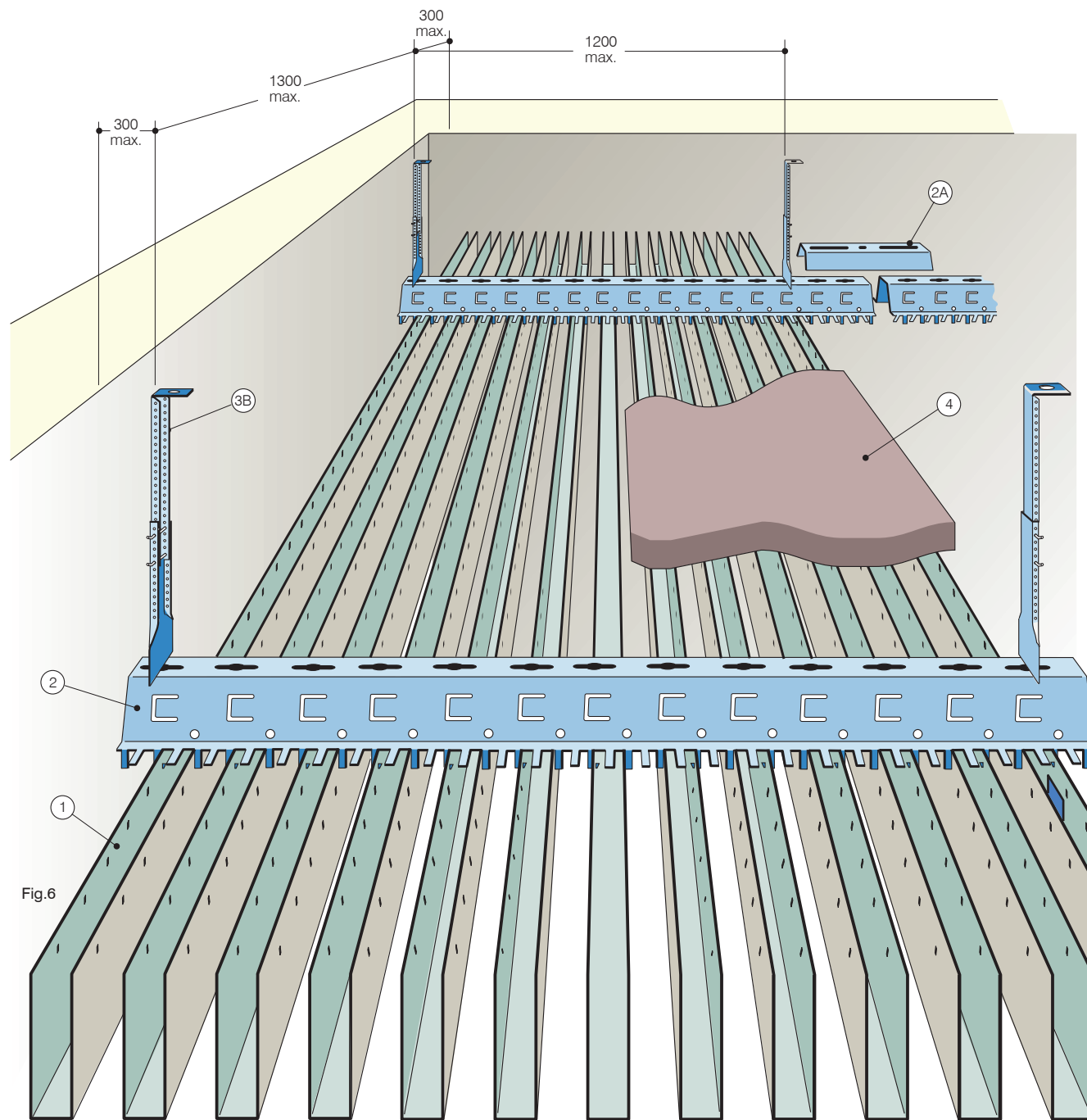

Fig.6

Suspended from the structural soffit by adjustable hangers (3B) [Fig. 6] or (3A) (see rear page), Omega carriers (2) [Figs. 2 & 3] contain preformed tongues in their base, spaced according to LINUS profile

module requirements. The tips of the tongues are aligned with minuscule slots preformed at 38mm centres [Fig. 3] in the sides of locally compressed sections of the LINUS

profiles (1) [Fig. 2]. When pressure is removed the tips penetrate the sides of the profile [Fig. 5] to make a secure attachment. Removal of the profiles is effected by this same action in reverse.

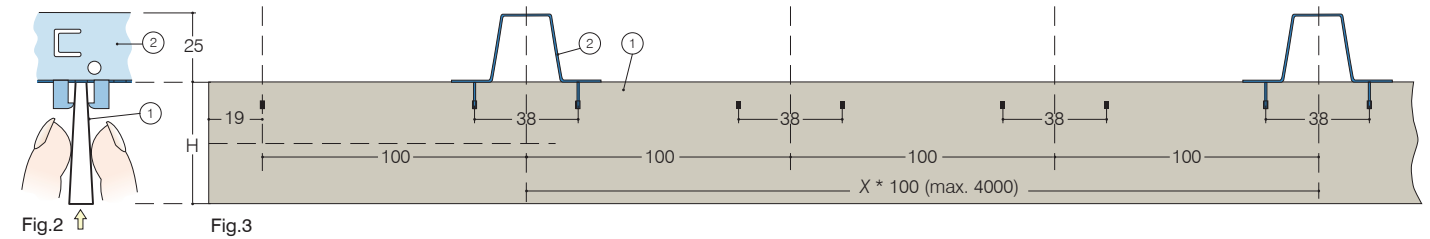

Fig.2

Fig.3

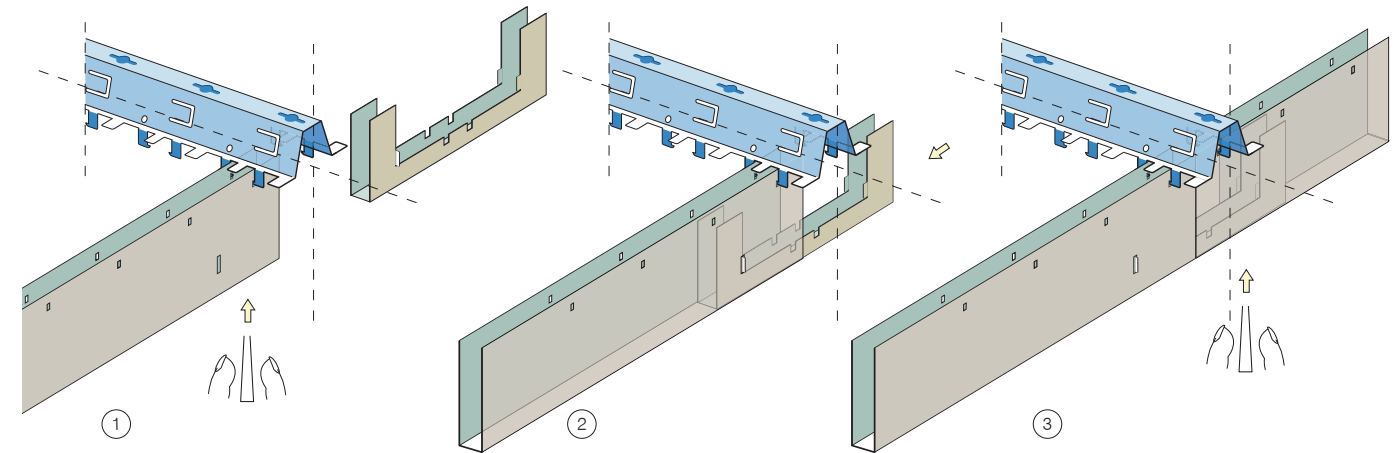

Fig.7 Linus profiles, schematic overview of the coupling. In order to obtain a more stable and straight alignment, Linus profiles are coupled at the carrier using a splice channel.

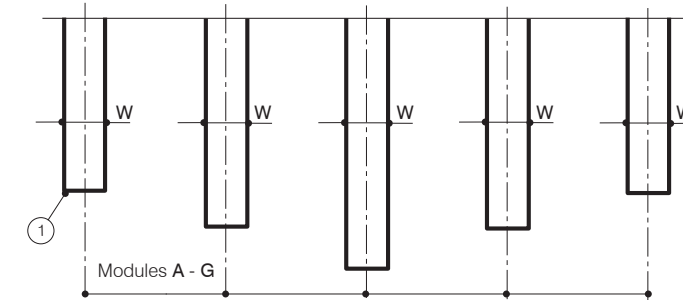

Fig.4 By varying the profile height, stepped or wave formation ceiling sections can also be created.

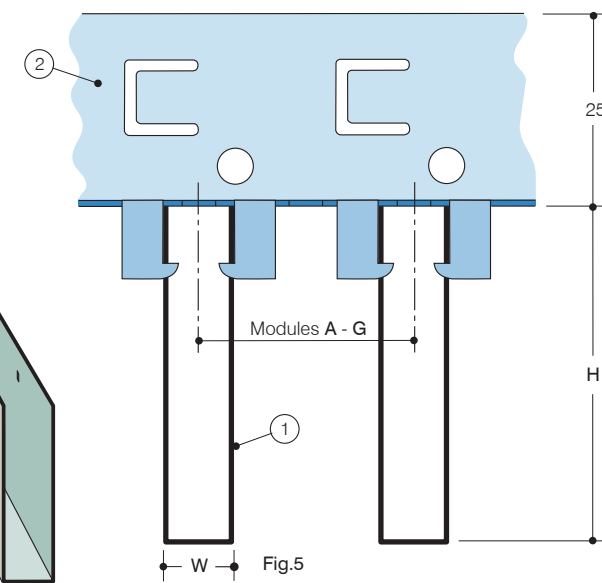

Fig.5

Generally speaking the ends of LINUS profiles are terminated a constant distance from walls perpendicular to their linear axis to form a floating edge effect, however, where this is considered inappropriate, perimeter angles (5i) or (6) or channel (5ii) (see rear page), can be used to cloak cut edges of LINUS profiles.

The LINUS system produces linear screen effect interior ceilings having the semblance of an overall continuous directional grill. Linear emphasis can be attuned to individual building designer preference by selecting from an extensive range of options. Manufactured from light gauge aluminium or mild steel, deep U formation LINUS profiles (1) [Fig. 5] are fixed as shown to suspended carriers (2) [Figs. 2, 3, 5 & 6] to create an open gap structure.

20 sizes of profile, each referenced according to its width (W) and height (H), see Table 1, are available, as are seven standard module carriers (2), see A to G, providing multiple choice of profile width and height and gap width.

By selecting a preferred module and profile width, but varying the profile height, stepped or wave formation ceiling sections like that seen in Fig. 4 can also be created.

The LINUS profiles are supplied in plain (non perforated) metals or in either of two perforated forms shown on the rear page. They are available in a selection of standard colours using stove enamel finish plus reflective or mirror finishes as listed in the company's colour chart.

Special finishes are subject to minimum order quantity. Ceilings overlaid with inert fibrous insulation material (4) [Fig. 6] act as sound absorbing membranes.

Please note that certified performance data in section 6 of our technical manual and typical specification layout is on sheet 2.07/1/21.

Table 1
Legend Linus module range and profile sizes.
H Linus profile height as Fig.5 in mm.
W Linus profile width as Fig.5 in mm.
Standard modules in mm.
A = 30 B = 35 C = 40 D = 50 E = 60 F = 75 G = 100
Modules in excess of 100mm can be supplied subject to quantity.

W	H	H	H	H	H	H	H	H
	30	35	40	45	50	55	60	80
10	A-G		A-G		A-G		A-G	
12			B-G		B-G		B-G	
15			B-G		B-G	B-G		B-G
20		C-G		C-G		C-G		C-G
24		D-G		D-G	D-G			D-G

Linus